

PARÇA KODU PART CODE	PARÇA ADI PART NAME	s ÖLÇÜSÜ (KALINLIK) s MEASURE (THICKNESS)	Malzeme Material	Kaplama / Coating		
				SN	AG	Ni
TÇ 2529 DP	3 NO ÇATAL Ø4.2 =DP=	0.5±0.05	(CuZn30) Pirinç / Brass	-	-	-
TÇ 2529 RP	3 NO ÇATAL Ø4.2 =RP=	0.5±0.05	(CuZn30) Pirinç / Brass	-	-	-
TÇ 2529 RPK	3 NO ÇATAL Ø4.2 =RPK=	0.5±0.05	(CuZn30) Pirinç + Kalay / Brass + Sn	+	-	-
TÇ 2529.60 RP	3 NO ÇATAL Ø4.2 =RP=	0.6±0.05	(CuZn30) Pirinç / Brass	-	-	-
TÇ 2529.60 RPK	3 NO ÇATAL Ø4.2 =RPK=	0.6±0.05	(CuZn30) Pirinç + Kalay / Brass + Sn	+	-	-

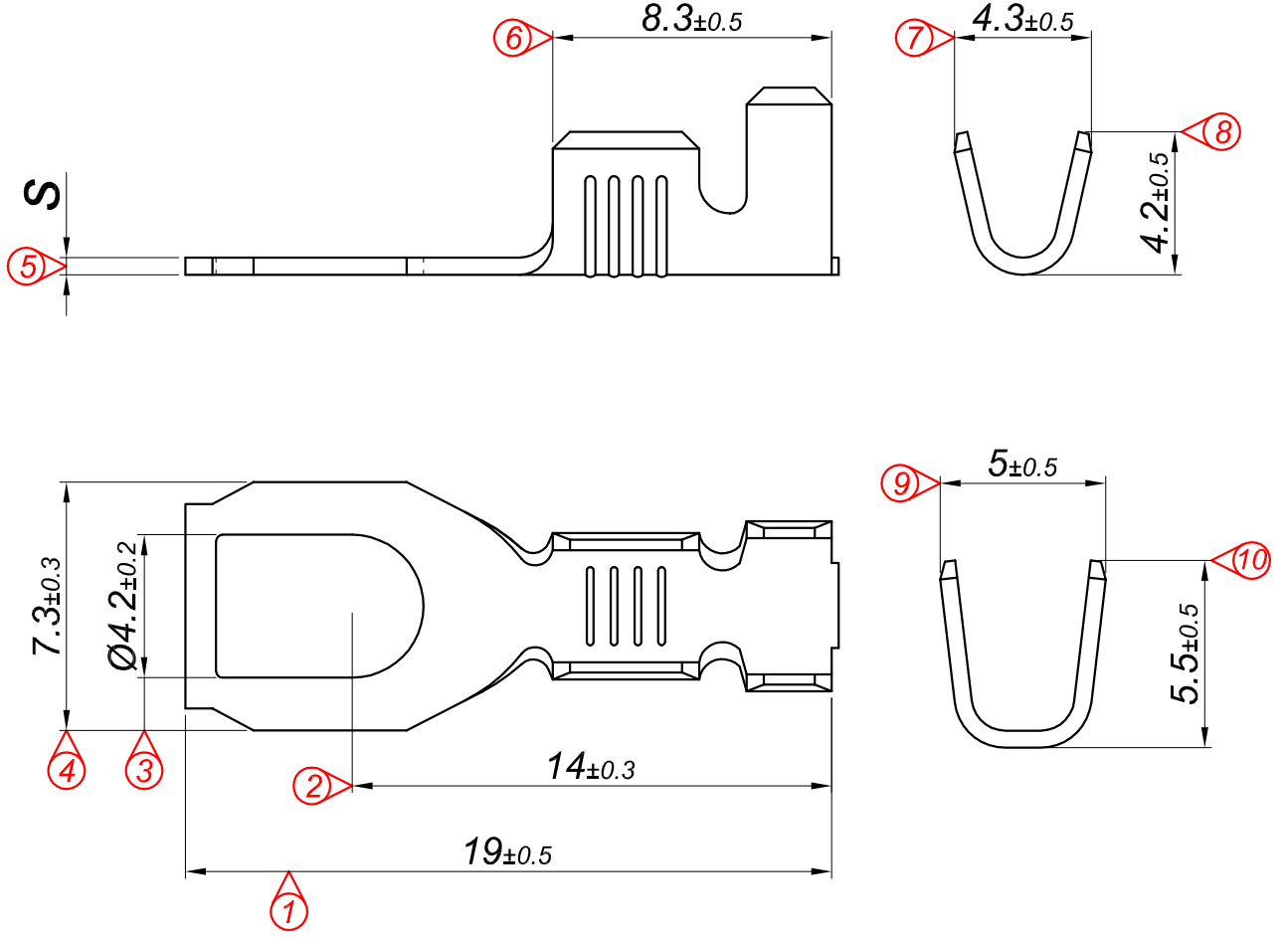



Kablo Kesiti

Wire Section : 1 - 2.50 mm²

Resmin Üzerinden Ölçü Almayınız

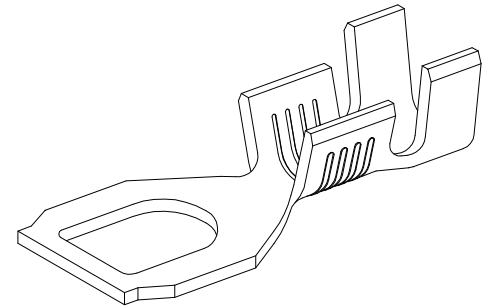
Don't use the drawing for measuring purpose



Tarih / Date	16.07.2014	İmza /Signature	Ölçek / Scale			
Çizen / Desing	M.Yağcı		5 / 1			
Onay / Approval	S.Gölcük			No	Değişiklik / Revision	Tarih/Date
	Parça Adı: Part Name	3 NO ÇATAL Ø4.2		Parça Kodu: Part Code	TÇ 2529	